

# MEP 2c DUAL CHANNEL PROGRAMMER.

## Installation Instruction

### 1.0: Precautions Against Electric Shock Hazard.



Installation and maintenance must be carried out only by suitably qualified personnel & in accordance with IEE wiring regulations. This equipment must not be mounted to metal or metalised surfaces that are not earth bonded. A fuse rated at 3 amps must be installed to protect the system installation. Disconnect mains supply before removing the equipment from its wiring plate, as terminals may be live.

Fixed wiring installation must be used. A class 'A' switch (having contact separation of 3mm minimum in all poles), must be incorporated in the fixed wiring as a means of supply disconnection.

Do not operate this equipment outside of its rated parameters, (current, voltage etc.). For example: do not wire directly to an immersion heater.

### 2.0: MEP 2c Technical Specification:

Function: Time control of domestic heating  
 Power Supply: 230Vac, 50Hz.  
 Switch Type: Two SPDT Relays, Type 1C  
 Switch Rating: 3 (3) amps, each switch

Ambient Operating Temperature: 4 to 45 degC  
 Storage Temperature: -20 to 55 degC  
 Battery Backup: Retains settings for 1 year.  
 Housing Material: Fire retardant ABS

Pollution Situation: Normal  
 Software Class: A.  
 Enclosure Protection: IP20  
 Enclosure Insulation: Class II.



### 3.0: Regulatory Compliance.

This product conforms to the essential requirements of EU Directives: 89/336/EEC, 92/31/EEC: Electromechanical Compatibility 73/23/EEC, 93/68/EEC: Low Voltage.



### 4.0: Wiring to Replace an Existing Programmer:

The MEP2c can be used to replace many existing programmers from other manufacturers. Refer to Table 1 and Table 2 below.

DIRECT REPLACEMENT: Simply remove existing programmer from wiring plate and fit the MEP2c to the wiring plate.				
Myson: 2MEP2c	Glow-Worm: Mastermind.	Honeywell: ST6200A ST6300A ST6400C ST6450B	Landis & Gyr: RWB2 RWB9 RWB69 RWB40 RWB200 RWB252 RWB270	
ACL-Drayton: LP112 LP241 LP522 LP722 LS241 LS522 LS722	Danfoss Randall: CP15 CP75 FP15 FP75 MP15 MP75	Horstmann: Centaur Plus C21 Centaur Plus C27		
SAME WIRING: Note down the existing wiring. Remove existing wiring plate. Fit MEP2c wiring plate per Section 5. Wire directly as per notes taken.				
ACL-Drayton: Tempus 3. Tempus 4. Tempus 6. Tempus 7.	Horstmann: Centaur TC1 Centaur TC7	Potterton: Miniminder E. Miniminder Es.	Towerchron: DP72 QE2.	

TABLE 1: DIRECT REPLACEMENT & SAME WIRING (SEE ALSO TABLE 2)

### 5.0: Mounting the MEP 2c Wiring Plate:

The wiring plate may be mounted either directly to the wall or to a single gang flush conduit box complying with BS1363 or BS4662. Allow clearance around the wiring plate as advised in figure 1. Fixing slots are provided in a number of locations on the wiring plate. Ensure that the mounting location allows easy access for adults but is out of the reach of children. The unit is for use in normal domestic environments only, and must not be installed in any location open to extremes of moisture, temperature, dust or other adverse conditions. Under no circumstances should the wiring plate be mounted to unearthed metal or metalised surfaces.

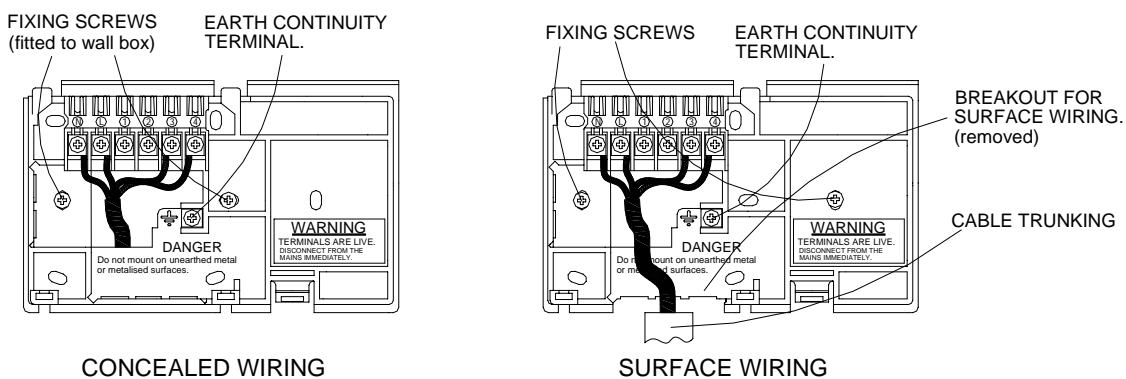

Minimum Clearance Distances: Above and below wiring plate: 50mm. Left and right of wiring plate: 25mm

Figure 1: Myson Wiring Plate

## 6.0: Wiring the MEP 2c Wiring Plate:

Concealed wiring is brought in through the rear of the wiring plate, (fig. 1). Surface wiring is brought in either from the left hand side or from the bottom where break-outs are provided on the edges of the plate to allow access for cables. The break-outs may be broken clear with pliers, (fig 1). Surface cables must be routed in cable trunking.

The MEP 2c employs double insulation and therefore does not itself require an earth connection. An earth continuity (loop) terminal is however provided on the wiring plate for interconnecting existing earth cables.

## 7.0: System Wiring:

The internal wiring circuit of the MEP2c is illustrated in Figure 2.

System wiring of the more common heating systems is illustrated in figure 7. Ensure that any such installation is in accordance with IEE regulations. Note that the control components, (valves etc.), displayed in figure 7 are Myson components. If non-Myson components are used, ensure that the wiring is appropriate to the product installed.

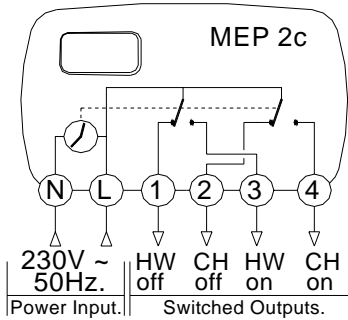

Figure 2: Internal Wiring.

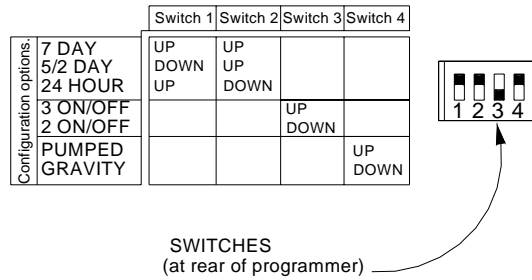

Figure 3: Configuration Switch Settings.

## 8.0: Configuring the Myson MEP 2c:

At the rear of the programmer is a configuration switch. Available options are:

### Data Entry Style:

7 DAY: ON/OFF times can differ from day to day.

5/2 DAY: ON/OFF times are the same Monday through Friday, and are the same on Saturday as on Sunday.

24 HOUR: ON/OFF times are the same for all seven days of the week.

### Number of Periods of Heat per Day:

3 ON/OFF: Heat in the morning, afternoon and evening

2 ON/OFF: Heat in the morning and in the evening.

### Hot Water Circulation:

PUMPED: For use in a pumped domestic hot water system.

GRAVITY: For use in a gravity domestic hot water system.

The switch settings corresponding to each of these options are illustrated in figure 3.

## 9.0: Fitting the Myson MEP2c to the Wiring Plate:

Where surface wiring has been used (Section 5), use pliers to remove the corresponding **breakout** from the **frame** of the programmer, (fig. 4).

Locate the programmer over the wiring plate at an angle as shown in figure 4. With the MEP2c wiring plate, the frame of the programmer passes underneath a **latching lip** on the wiring plate. The latching lip is not present on non-Myson wiring plates. Ensure that the two **tab receptacles** of the programmer are positioned directly over the two **tabs** of the wiring plate.

Rotate the programmer downwards into position so that it fully covers the wiring plate. Ensure that no conductors are exposed and that there is no possibility of access to any conductors.

The MEP 2c wiring plate possesses a **latching clip**, (fig. 5), which locks the programmer to the wiring plate. Check that the clip has adequately secured the programmer. On non-Myson wiring plates, engage the two **captive screws** of the wiring plate in the two **screw slots** of the programmer frame, (fig. 6). Tighten the screws ensuring that the screw heads are seated in the depression provided.

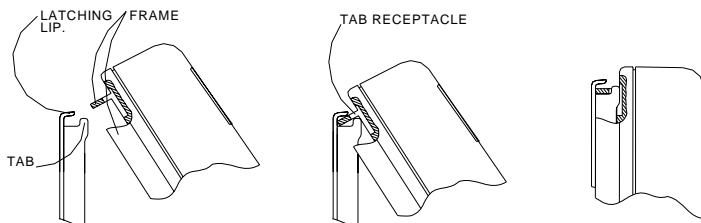

Fig 4. Fitting Programmer to Wiring Plate

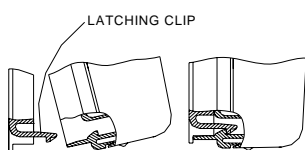

Fig 5. Myson Wiring Plate

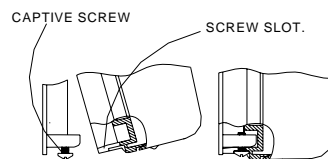

Fig 6. Non-Myson Wiring Plate

## 10.0: Handover to User:

Check that the programmer operates the heating system correctly and safely. Ensure all technical literature reaches the homeowner. Leave the dust cover provided in place over the programmer to protect it until handover to the homeowner

Remove the existing backplate, fit the MYSON MEP 2c backplate & wire existing wires to the terminals of the MYSON backplate as shown below.(note: identify and mark wires before removing from the existing backplate)

		MYSON MEP 2c TERMINALS							
		E	N	L	1	2	3	4	NONE**
MANUFACTURER	MODEL								
ACL-Drayton	LS112	E	N	L	2		3	4	
	FP	E	2	1	8	11	6	10	3
	MP	E	2	1			6	10	3,7,8
	Switchmaster 320	E	N,2	L			3	1	
	Switchmaster 350	E	N,2	L			3	1	
	Switchmaster 400	E	N	L		4	3	1	2
	Switchmaster 600	E	N	L			3	1	2,4
	Switchmaster 805	E	N	L	4	2	3	1	
	Switchmaster 900	E	N	L	4	2	3	1	A,B,C
	Switchmaster 9000	E	N	L	4	2	3	1	A,B,C
	Switchmaster 9001	E	N	L	4	2	3	1	A,B,C
	Switchmaster 905	E	N	L	4	2	3	1	
	Switchmaster Sonato		N	L	3	6	1	4	
Danfoss Randall	102	E	5	6			1	2	
	102E	E	5	6			1	2	
	102E5	E	5	6			1	2	
	102E7	E	5	6			1	2	
	3020P	8	1,7	6			4	2	3,5
	3033	8	1,7	6	5	3	4	2	
	3060	8	1,7	6			4	2	3,5
	4033	8	7	6	5	3	4	2	
	701	E	N	L	4	2	3	1	
	702	E	N	L	4	2	3	1	
	922	E	N	L	1	4	3	6	
972	E	N	L	1	4	3	6		
Honeywell	ST699B - Fully pumped	E	N	L	7	4	6	3	
	ST699B - Gravity	E	N	L			8	3	
	ST 7000A		N	L	2		3	4	
	ST 7100	E	N	L	7	4	8	5	
	ST 799A		N	L	7	4	6	3	
Horstmann	423 Amethyst 10	E	2,3	1	4	6	5	7	
	423 Amethyst 7	E	2,3	1	4	6	5	7	
	423 Diamond	E	N	L			2	4	5,6
	424 Coral	E	2,3	1			8	4	5,6
	424 Diamond	E	N	L/1			2	4	5
	424 Gem	E	2,3	1	6	9	4	7	
Landis & Gyr	RWB 20		N	L	1	2	3	4	
Pegler Sunvic	MP2		N	L	hw off		hw on	ch on	
	SP100	E	N	L	1	4	2	5	S,S
	SP25	E	N	L	1		2	5	S,S,4
	SP30	E	N	L	1		2	5	S,S,4
	SP50	E	N	L	1	4	2	5	S,S
Potterton	EP2000	E	N	L	1	2	3	4	A,B,C,D
	EP2001	E	N	L	1	2	3	4	A,B,C,D
	EP2002	E	N	L	1	2	3	4	A,B,C,D
	EP3000	E	N	L	1	2	3	4	A,B,C,D
	EP3001	E	N	L	1	2	3	4	A,B,C,D
	EP3002	E	N	L	1	2	3	4	A,B,C,D
	EP6000	E	N	L	1	2	3	4	A,B,C,D
	EP6002	E	N	L	1	2	3	4	A,B,C,D
Myson	Microtimer	E	N	L	7		6	3	
Sangamo	M5	E	4,5	3			1	6	
Smiths Industries	Centroller 100	E	N	L			3	2	1,4
	Centroller 60	E	1	2			5	4	3,6
	Centroller 70	E	1	2			5	4	3,6
	Centroller 90	E	1	2			5	4	3,6
Towerchron	T2002	E	N	L			hw on	ch on	
	T2002Q	E	N	L			hw on	ch on	
	T2003	E	N	L	hw off	ch off	hw on	ch on	
	T2003Q	E	N	L	hw off	ch off	hw on	ch on	
Venner	CHC/W2	E	N,2,4	L			1	A/S	A/S,3
	Venetrol 80	E	N,1,3,4	L			2	A/S	A/S,5
	Venetrol 80M	E	N,3	L	1	4	2	A/S	A/S,5
	Venetrol 80P	E	N,1,3	L			2	A/S	A,S,4,5
	Venetrol80P/M	E	N,3	L	1	4	2	A/S	A/S,5
	Venetrol T20	E	N	L			1	4	
	Venetrol T30	E	N	L	1	3	2	4	

\*\* not used with the MEP 2c. Make safe the exposed ends of these wires & fold out of the way.

Table 2: Replacing an Existing Backplate and Rewiring (See also Table 1)

### TYPICAL DIVERTER/ MID-POSITION VALVE SYSTEM.

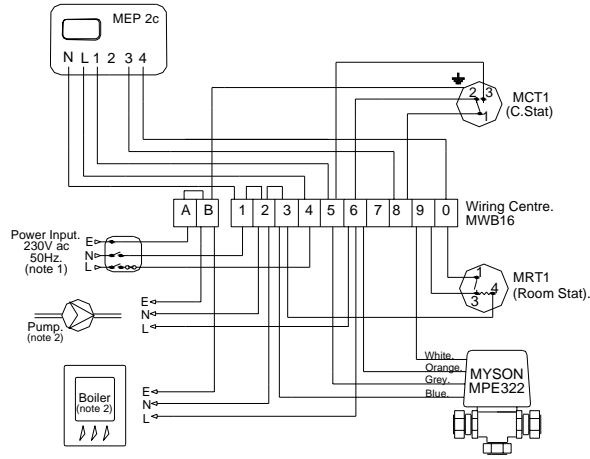
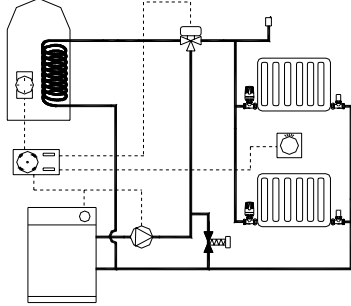

### TYPICAL ZONE VALVE SYSTEM.

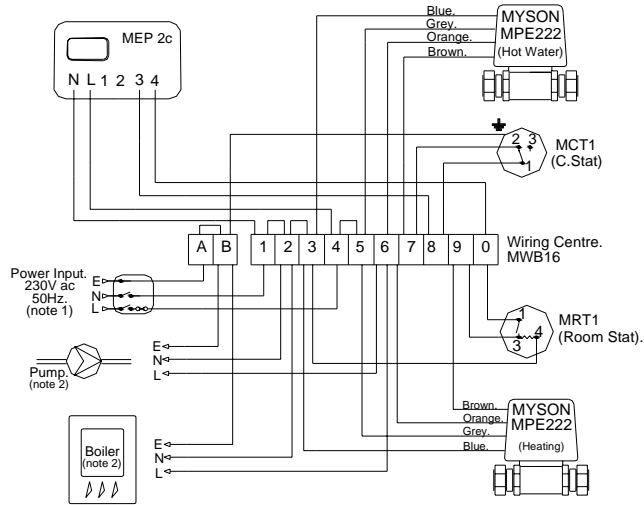
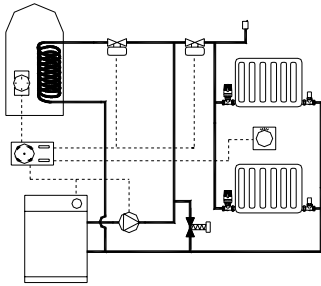

### TYPICAL GRAVITY HOT WATER SYSTEM.

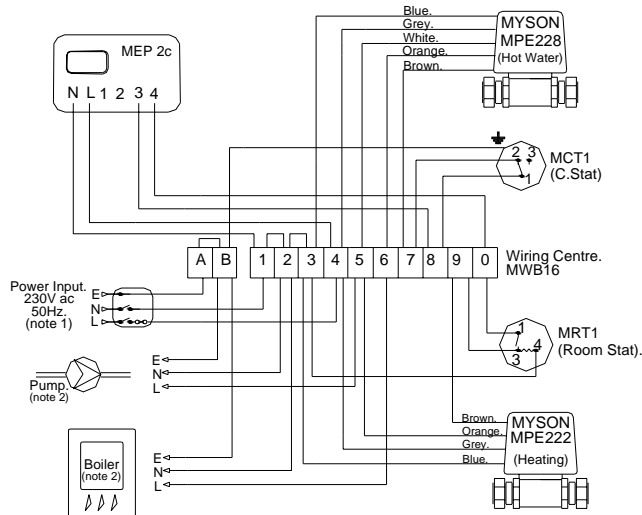
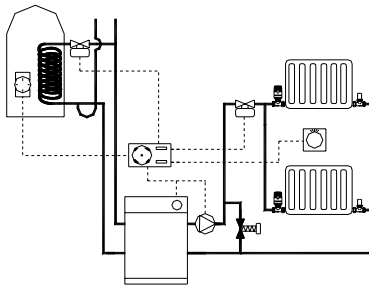

Note 1: A Class 'A' switch, (contact separation of at least 3mm in all poles) must be incorporated in the fixed wiring as a means of disconnecting the supply voltage.  
To avoid electric shock, disconnect mains supply before doing any maintenance or installation work.  
To protect the system a fuse rated at 3 amps must be installed.  
To avoid electric shock installation or repair must be carried out by suitably qualified personnel and in accordance with current IEE regulations.

Note 2: Refer to the boiler and pump manufacturers wiring instructions to determine their precise wiring requirements, with particular reference to pump "over-run".

Figure 7: Typical System Wiring.



# MYSON

MYSON LTD., EASTERN AVENUE, TEAM VALLEY, GATESHEAD  
TYNE & WEAR, NE11 0PG  
SALES OFFICE No.: 0845 402 3434

IN ACCORDANCE WITH OUR POLICY OF CONTINUAL PRODUCT IMPROVEMENT, WE RESERVE THE RIGHT TO AMEND THE SPECIFICATION OF THESE PRODUCTS WITHOUT PRIOR NOTIFICATION

SC1796: Rev 10.

# MEP2c DUAL CHANNEL PROGRAMMER.

## User Instruction.

This programmer will switch your central heating and domestic hot water on/off at your chosen times. You simply enter the 'on' and 'off' times you require and run the programmer.

Key to abbreviations: CH: Central Heating. DHW: Domestic Hot Water.

### **1: Precautions Against Electric Shock Hazard:**



Detaching your programmer from the wall exposes electrically live terminals in the same way as removing the cover from a mains wall socket exposes live terminals. The programmer is detached from the wall by unlatching the clip underneath the flap. This should only be performed by suitably qualified personnel and with the power switched off.

Ensure that your programmer has been installed by a qualified professional. Installation by non professionals could result in serious injury. As an added precaution ensure your programmer has been mounted in a location out of the reach of children.

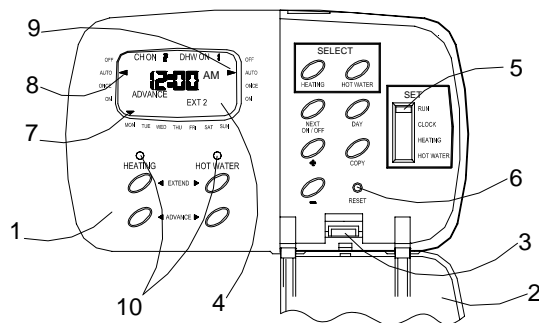

- 1: Programmer.
- 2: Flap, (in opened position).
- 3: Clip for releasing programmer from wiring plate
- 4: Display.
- 5: SET Switch.
- 6: Reset button.
- 7: Day pointer.
- 8: CH Run Pointer.
- 9: DHW Run Pointer.
- 10: Status lights.

### **2: Setting the Clock:**

The clock will automatically correct itself for winter/summer time changes. However should the clock need adjustment use the following instructions. Move the SET switch to CLOCK. Both the time and day pointer will be blinking. Press the DAY button until the day pointer points to the correct day. Use the + and – buttons to set the correct time. Press the NEXT button. The date will blink. Set using the + and – buttons. Press NEXT again. The month will blink. Set by using the + and – buttons again. Press NEXT and use the + and – buttons to set the first two digits of the year. Press NEXT and use the + and – buttons to set the final two digits of the year. Move the set switch back to RUN.

### **3: Entering on/off Times:**

#### *3.1: Entering Heating on/off times:*

Move the set switch to HEATING. "CH ON 1" will blink indicating that the heating is set to come 'on' at the time displayed. Use the + and – buttons to set the time you require.

Press NEXT: the display shows "CH OFF 1" and the switch 'off' time. Adjust if required.

Press NEXT again to set the 'on' time for your second heating period, (CH ON 2).

Press NEXT again to set CH OFF 2.

Press NEXT again: depending on your programmer set up "CH ON 1" or "CH ON 3" will be displayed.

If "CH ON 1" is displayed, your programmer has been set-up to give two heating periods per day. You have already set the times for both these periods and can now go to paragraph 3.2. (see notes 1).

If "CH ON 3" is displayed, your programmer has been set-up to give three heating periods per day. Enter the times for the third period in the same way as for the previous period and proceed to paragraph 3.2. (see notes 1).

#### *3.2: Heating on/off Times for the Rest of the Week:*

Depending on how your programmer has been set-up, (see note 1), the day pointer, (on the display), will be in one of three formats:

**a) Pointer appears at all seven days.** The times entered in step 3.1 apply to all seven days. In this set up you do not have the option to change individual days. (see note 1). Proceed to step 3.3.

**b) The pointer appears at one day only:** The times entered in step 3.1 apply to one day only. Press the COPY button. The pointer moves to the next day, copying the settings from the first day. If required, modify the settings using the +, -, and NEXT buttons. Repeat the process for the remaining days and proceed to step 3.3.

**c) The pointer appears at either the five week days or the two weekend days.** The times entered in step 3.1 apply to either the weekdays or to the weekend days. Press COPY. The pointer moves to the other group of days copying the times in the process. Modify if required using the + and - buttons. Proceed to paragraph 3.3.

#### *3.3: Entering Hot Water on/off Times:*

Move the SET switch to HOT WATER and repeat the procedure of 3.1 & 3.2 above. Now proceed to paragraph 4.

## **4: Running the Programmer:**

### *4.1: To run the programmer:*

Move the SET switch to RUN. Both CH and DHW run pointers point to AUTO. "AUTO" indicates that the programmer will switch on/off at the times entered. Press the SELECT HEATING button. The CH pointer moves to ONCE. "ONCE" indicates that the heating will come on at the first 'on', (CH ON 1) and remain on until the last 'off'. This is an "on by day" and "off by night" option. Press the SELECT HEATING button again. The pointer moves to ON. The heating will remain on constantly, by day and by night. Press the SELECT HEATING button again. The pointer moves to OFF. The heating will remain off constantly. Press the SELECT HEATING button again. The pointer returns to AUTO.

In a similar fashion the SELECT HOT WATER button enables you to cycle through the four hot water options, AUTO, ONCE, ON and OFF.

### *4.2: Information Displayed when Programmer is Running:*

When the programmer is running the display provides the following information: the current day; the current time; the run option chosen, (AUTO, ONCE, ON, OFF); and whether your heating or hot water is currently on or off. Additionally, if you are running in AUTO, you are told which on/off period is current. For example: CH ON 2 tells you that you are in the second heat period. There are also red status lights on the front of the programmer. The left one applies to central heating and the right one to hot water. When the lights are on the heating or hot water is on, and when they are off the heating or hot water is off.

## **5: Additional Functions:**

EXTEND & ADVANCE are functions you may find useful. They operate in AUTO mode and are explained below.

### *5.1: ADVANCE:*

If your heating is 'on', pressing HEATING ADVANCE will switch it off. It will remain off until the next 'on' time.

If your heating is 'off', pressing HEATING ADVANCE will switch it on. It will remain on until the next 'off' time.

"ADVANCE" is visible on the CH side of the display. If you press ADVANCE again, the ADVANCE is cancelled.

HOT WATER ADVANCE works in a similar fashion to HEATING ADVANCE.

### *5.2: EXTEND:*

If your heating is 'off' pressing HEATING EXTEND will bring the heat on for one hour, (or until it reaches the next programmed 'on', whichever comes first). If you press it twice the heat will come on for two hours and if you press it three times the heat will come on for three hours. Pressing it four times will cancel the EXTEND function.

"EXT 1", "EXT 2", or "EXT 3" as appropriate appear on the CH side of the display.

If your heating is 'on', pressing HEATING EXTEND adds an extra hour to the normal 'on' period. If you press it twice, two extra hours are added and if you press it three times, three extra hours are added. Pressing it four times will cancel the EXTEND function.

"EXT 1", "EXT 2", or "EXT 3" as appropriate appear on the CH side of the display.

HOT WATER EXTEND works in a similar fashion to HEATING EXTEND.

## **6: General:**

### *6.1: Power Failure:*

The programmer has a memory backup that saves all settings for one year following loss of mains power. In the event of longer power-cuts the date, time and on/off settings will have to be re-entered.

### *6.2: Maintenance:*

Your programmer is a maintenance free device. In the event of a minor problem such as loss of display or programmer hang-up, press and hold the RESET button for 2 seconds. This will return your on/off settings to default settings. You will have to re-enter your on/off times. In the event of a more serious problem contact a professional. Do not attempt to remove the programmer from the wall as removal results in live wires being exposed on the wiring plate.

Note 1: Your programmer set-up can be altered. This action can only be performed by a qualified professional



MYSON LTD., EASTERN AVENUE, TEAM VALLEY, GATESHEAD  
TYNE & WEAR, NE11 0PG

SALES OFFICE No.: 0845 402 3434

IN ACCORDANCE WITH OUR POLICY OF CONTINUAL PRODUCT IMPROVEMENT, WE RESERVE THE RIGHT TO AMEND THE SPECIFICATION OF THESE PRODUCTS WITHOUT PRIOR NOTIFICATION

SC1798: Revision 9